



INSTALLATION INSTRUCTIONS

Accessory

AUTOMATIC DAY/NIGHT MIRROR

Application

2012 RIDGELINE

Publications No.

All 12005

Issue Date

NOV 2011

PARTS LIST

**Automatic Day/Night Mirror Kit
P/N 08V03-SDA-100B**

Day/night mirror

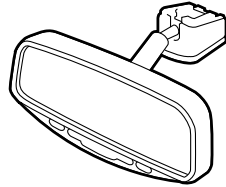

Spring



**Automatic Day/Night Mirror Attachment Kit
P/N 08V03-SJC-102**

Upper cover

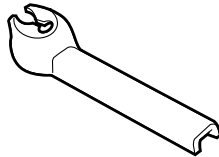

Lower cover

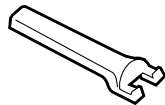

Mirror harness

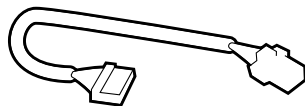

3 Wire ties

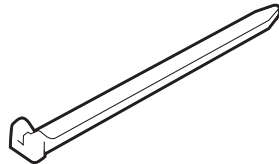

EPT Sealer

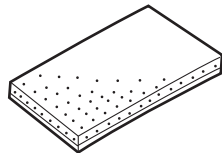

Owner's manual

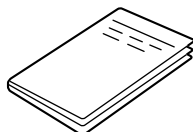

TOOLS AND SUPPLIES REQUIRED

Phillips screwdriver

Flat-tip screwdriver

Small flat-tip screwdriver

10 mm Combination wrench

Diagonal cutters

Ratchet

8 mm and 10 mm Socket

Tape measure

Long nose pliers

Isopropyl alcohol

Shop towel

Illustration of the Day/Night Mirror installed in the Vehicle

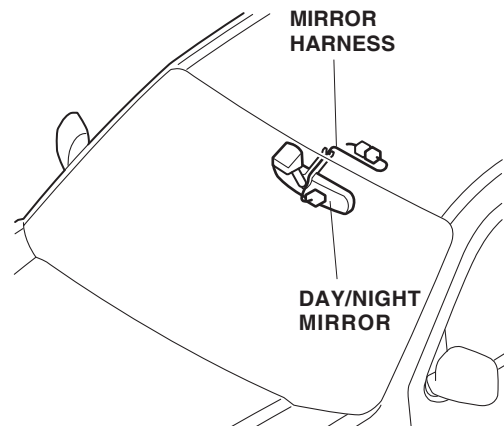

INSTALLATION

Customer Information: The information in this installation instruction is intended for use only by skilled technicians who have the proper tools, equipment, and training to correctly and safely add equipment to your vehicle. These procedures should not be attempted by "do-it-yourselfers."

1. Make sure you have the anti-theft code for the radio, then write down the radio station presets.
2. Disconnect the negative cable from the battery.
3. Remove the left and right lenses from the roof console (four retaining tabs).

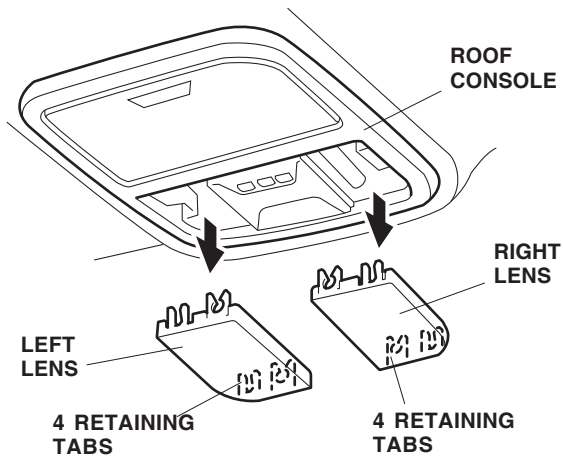

4. Remove the roof console (two bolts, two self-tapping screws, and unplug two connectors).

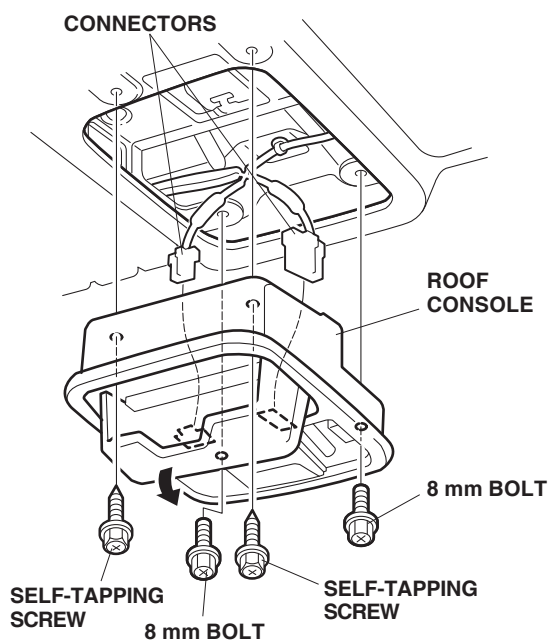

5. Remove the sunvisor holders. Using a flat-tip screwdriver, push the hook, turn the holder 90°, then pull it out.

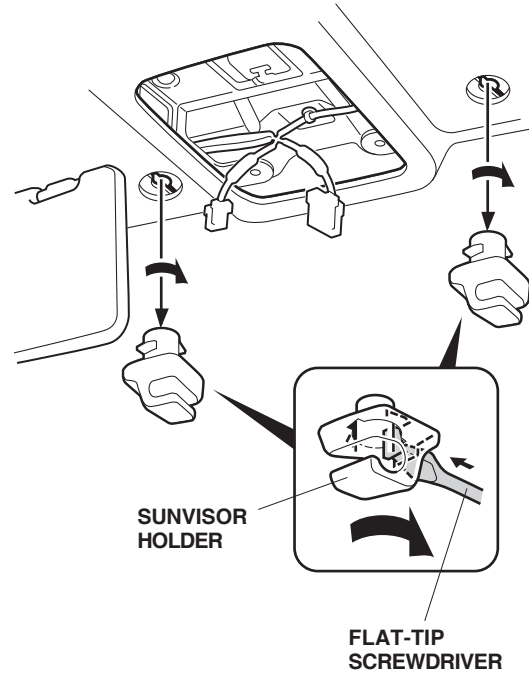

6. Remove the two bolts that fasten the vehicle bracket, and remove the vehicle bracket.

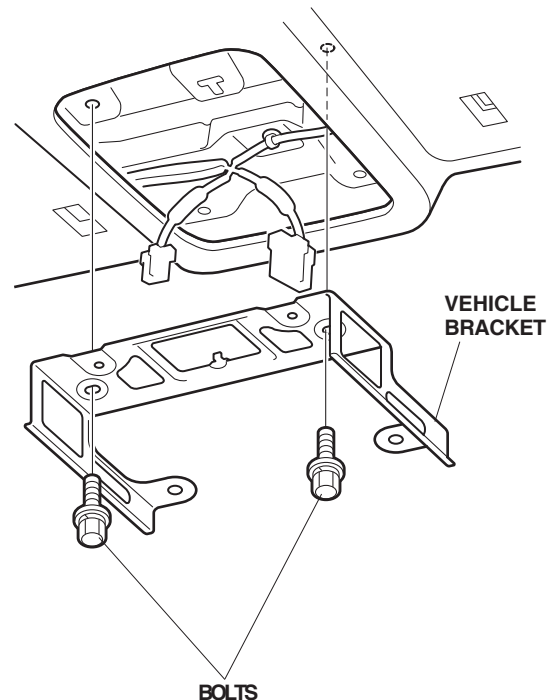

7. **With compass;** remove the upper and lower cover (two retaining tabs for each cover).

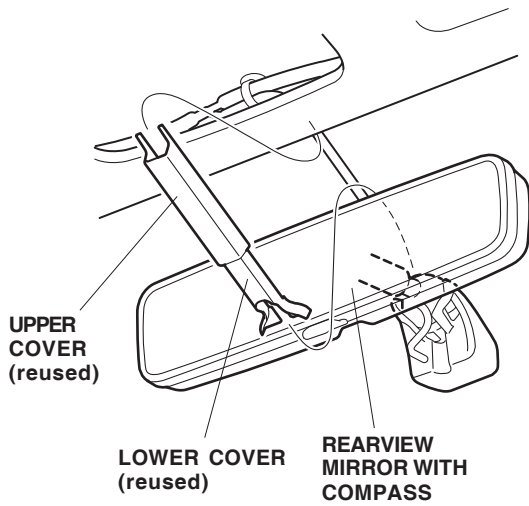

8. **With compass;** disconnect the vehicle harness 7-pin connector from the vehicle harness and from the rearview mirror. Set the vehicle harness aside; it will not be reused.

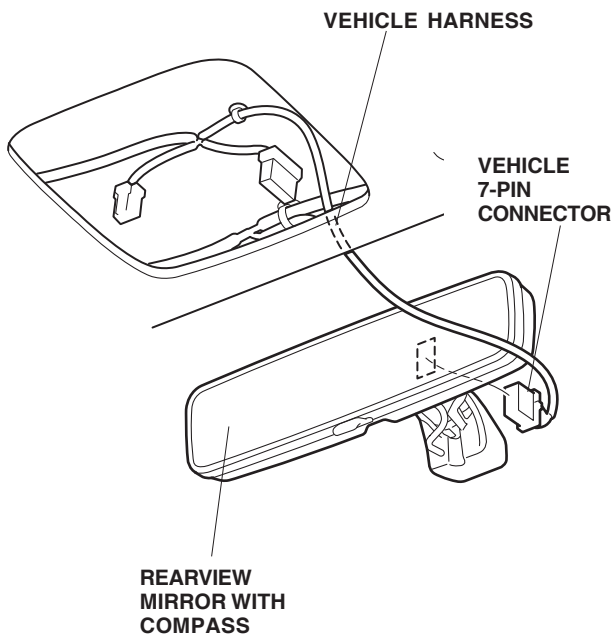

9. Remove the rearview mirror from the holder by rotating the stay clockwise.

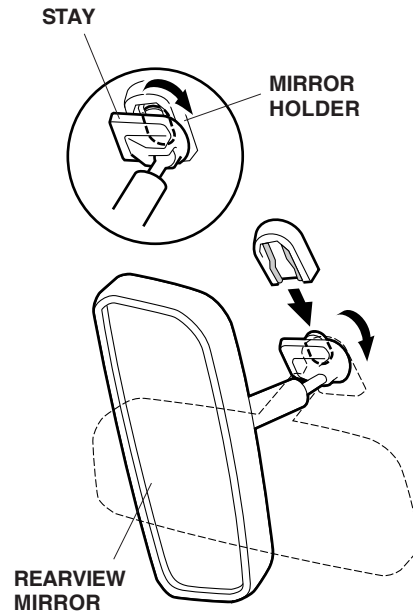

10. Remove and discard the mirror spring. Install the new spring from the kit to the mirror holder. Slide the day/night mirror stay onto the mirror holder, then turn the mirror stay counterclockwise as shown.

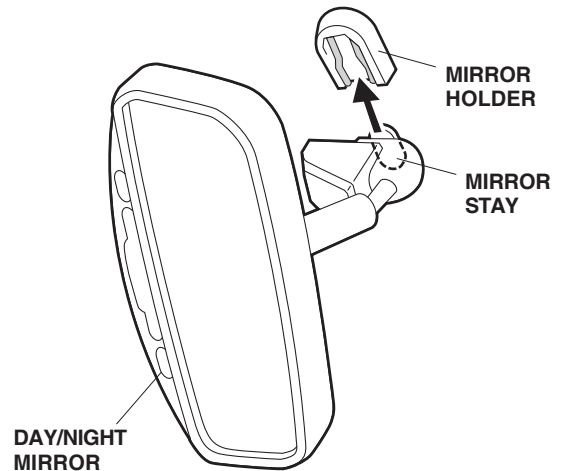
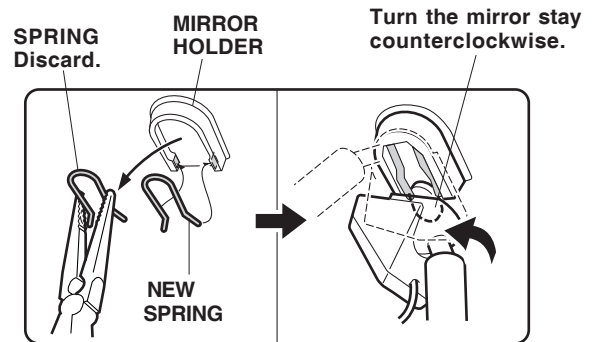

11. Plug the mirror harness 7-pin connector into the rear of the mirror, then route the 4-pin connector up and out through the console opening in the headliner. Make sure the wires coming out of the mirror harness 7-pin connector are not visible. If necessary, slide the tube toward the 7-pin connector.

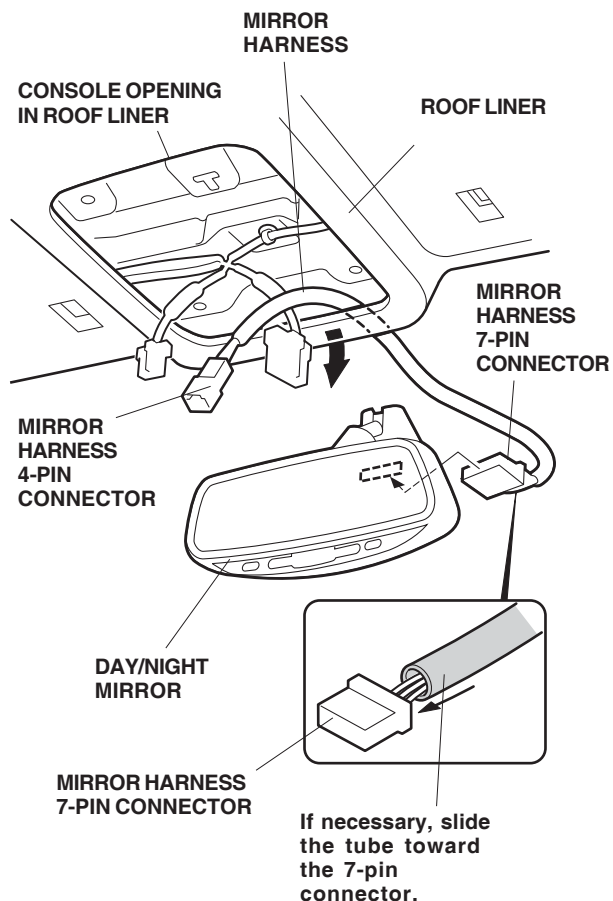

12. Attach the lower cover.

Without compass: Measure the mirror harness in the area shown. Get the upper and lower covers from the kit. Slide the end of the upper cover into the lower cover, then route the mirror harness through the grooves in the covers. Attach the lower cover to the mirror stay.

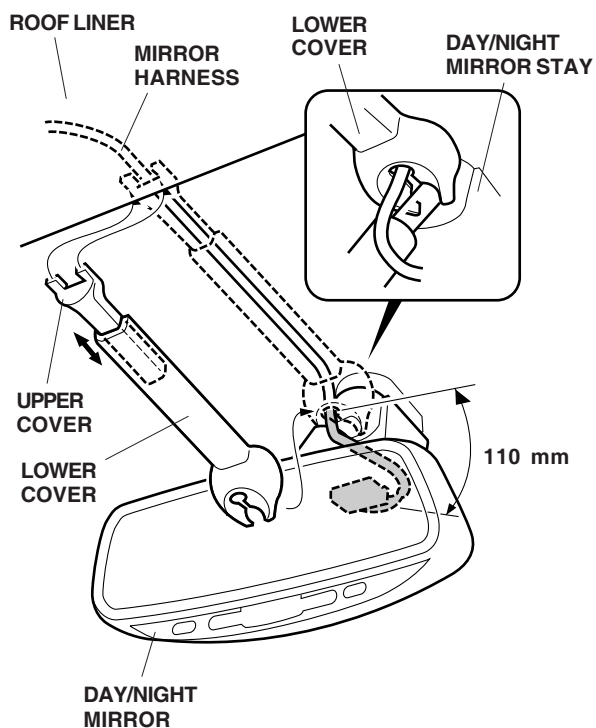

With compass: Measure the mirror harness in the area shown. Get the upper and lower covers removed in step 7. Slide the end of the upper cover into the lower cover, then route the mirror harness through the grooves in the covers. Attach the lower cover to the mirror stay.

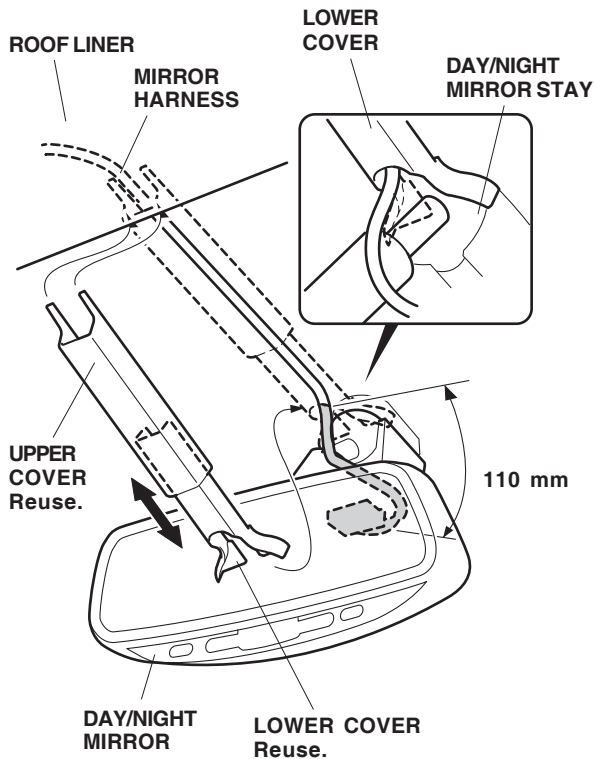

13. Locate the vehicle 4-pin connector blue-taped to the vehicle harness, and remove the tape to free the connector. Plug the mirror harness 4-pin connector into the vehicle 4-pin connector.

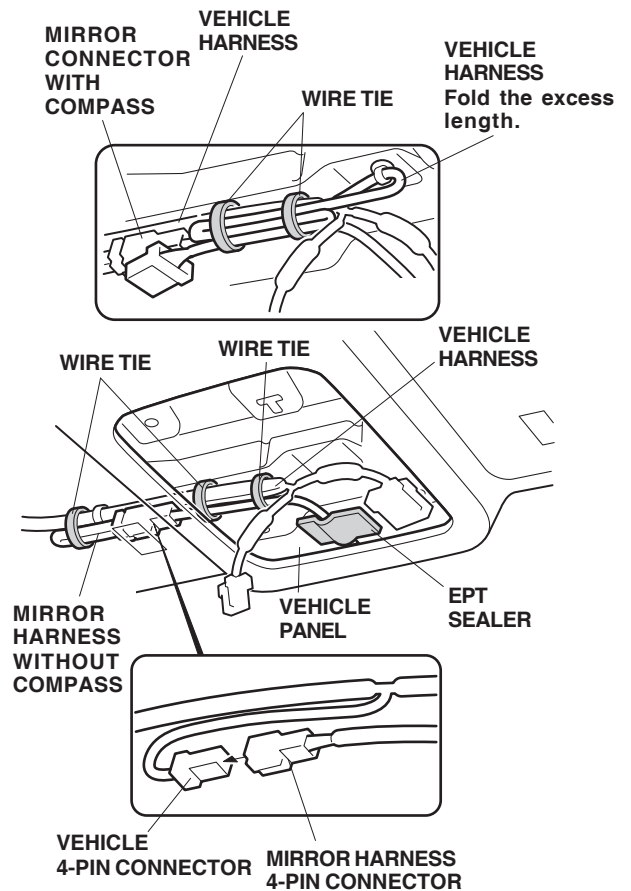

14. Secure the mirror harness to the vehicle harness.

Without compass: Secure the mirror harness to the vehicle harness with three wire ties.

With compass: Fold the excess length of the mirror harness, and secure the vehicle harness and mirror harness to the vehicle harness with two wire ties.

15. Using isopropyl alcohol on a shop towel, clean the areas where the EPT sealer will attach. Secure the mirror harness to the vehicle panel with the EPT sealer.

16. Check that all wire harnesses and cables are routed properly and that all connectors are plugged in.
17. Reinstall all removed parts. Check that all clips and fasteners are installed securely.
18. Reconnect the negative cable to the battery.
19. Enter the customer's radio anti-theft code, and reset the radio station presets.
20. Reset the clock.
21. Check the operation of the automatic day/night mirror according to the owner's manual supplied.

NOTE: Whenever the battery is disconnected, the driver's window AUTO function is disabled.

22. Start the engine. Push down on the driver's window switch until the window is fully open.
23. Pull up on the driver's window switch fully to close the window completely, then hold the switch for 2 seconds or more.
24. Test the window AUTO function.