



# INSTALLATION INSTRUCTIONS

Accessory	Application	Publications No.
<b>AUTOMATIC DAY/NIGHT MIRROR</b>	<b>2010 ODYSSEY</b>	<b>All 41817</b>
		Issue Date
		<b>JUNE 2009</b>

## PARTS LIST

**Automatic Day/Night Mirror Kit**  
P/N 08V03-S9A-100B

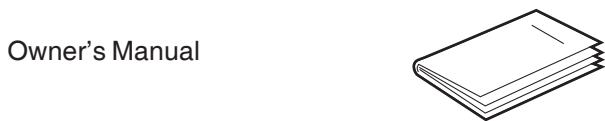

**Automatic Day/Night Mirror Attachment Kit**  
P/N 08V03-SHJ-101



## TOOLS AND SUPPLIES REQUIRED

- Phillips screwdriver
- Flat-tip screwdriver
- 8 mm Socket
- Ratchet
- T20 Torx bit
- Isopropyl alcohol
- Shop towel
- Clip remover

## Illustration of the Day/Night Mirror Installed on the Vehicle

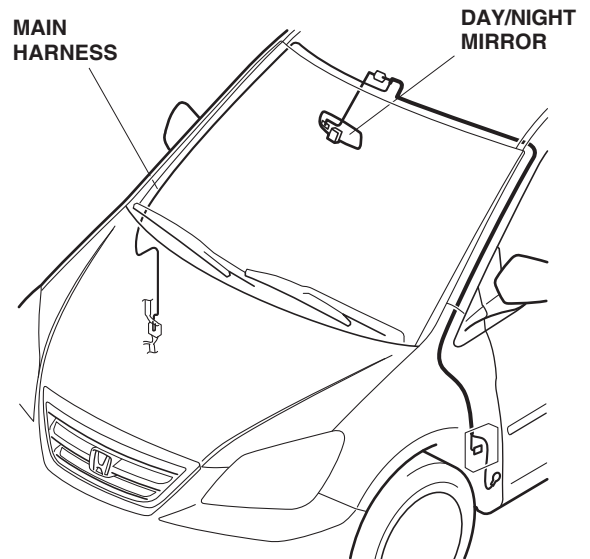

## INSTALLATION

**Customer Information:** The information in this installation instruction is intended for use only by skilled technicians who have the proper tools, equipment, and training to correctly and safely add equipment to your vehicle. These procedures should not be attempted by "do-it-yourselfers."

1. Make sure you have the anti-theft code for the radio, then write down the radio station presets.
2. Disconnect the negative cable from the battery.

- Remove the mirror by lifting it up out of the mirror base.

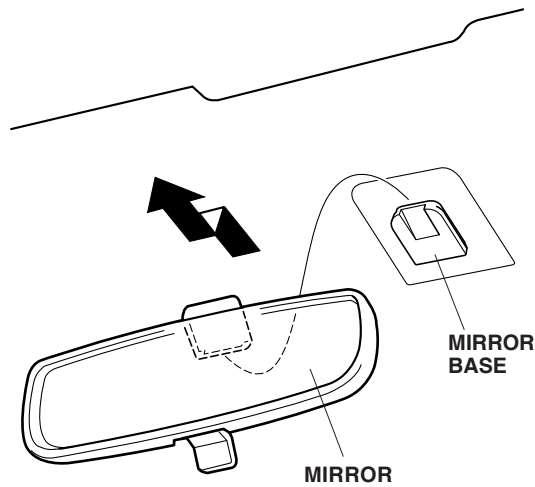

- Remove the right and left map light lenses (four tabs for each lens).
- Remove the two 5 mm bolts and two ground bolts, and pull out the roof console.

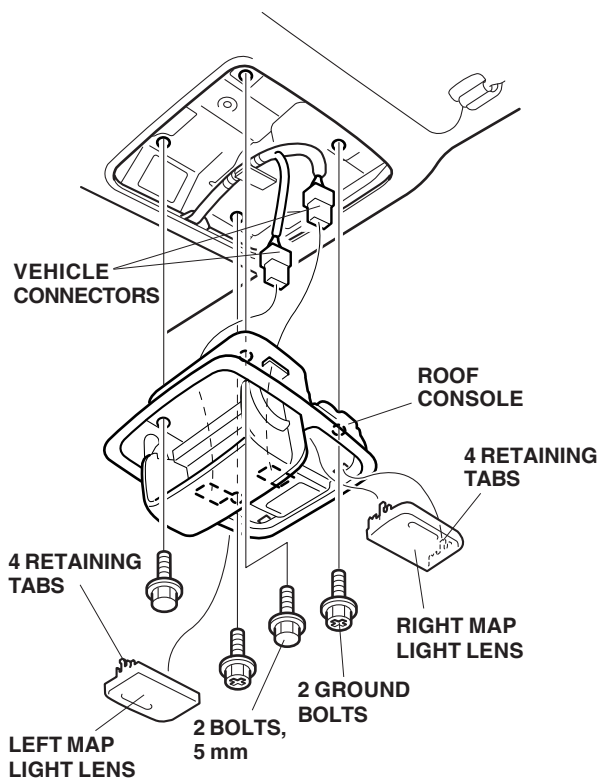

- Disconnect the two vehicle connectors, and remove the roof console.

- Remove the two retaining tabs, and remove the cover from the left sunvisor.

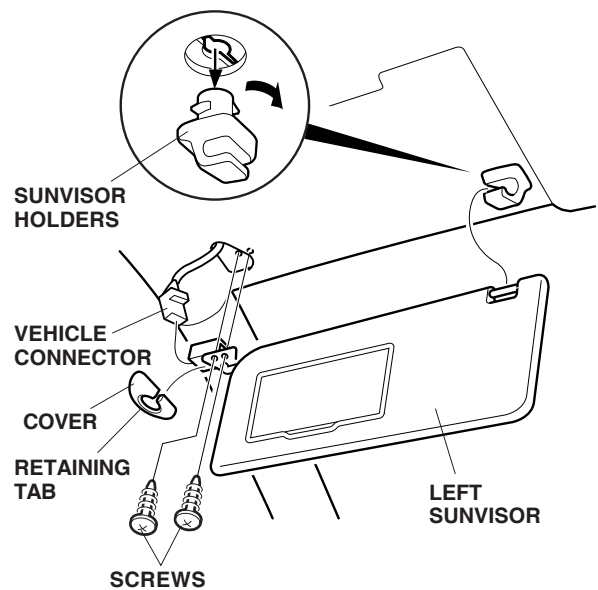

- Remove the two screws, pull out the left sunvisor, disconnect the vehicle connector, and remove the sunvisor.
- Repeat steps 7 and 8 to remove the right sunvisor.
- Remove the right and left sunvisor holders.
- Remove the door seal from around the left A pillar trim. Release the side curtain air bag clip and remove the left A pillar trim (two clips).

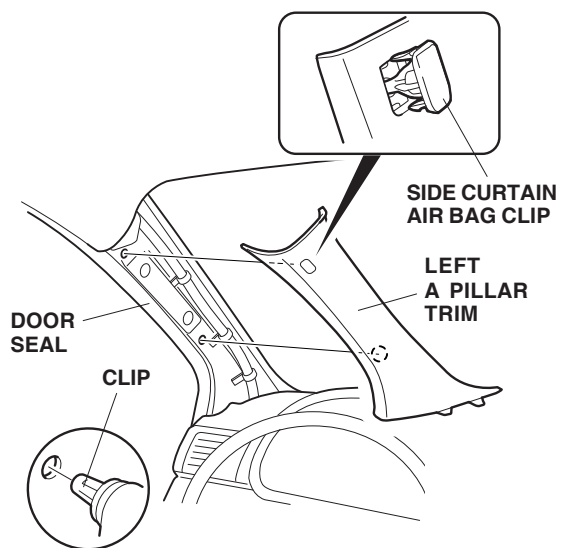

- Remove the right front A pillar trim the same way.

13. Remove the left front door sill trim (three clips).

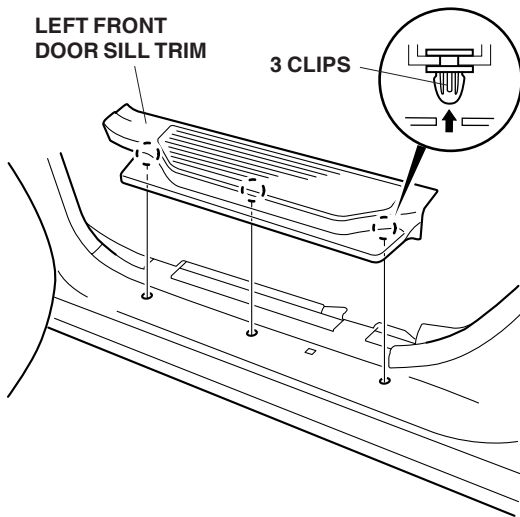

14. Remove the right front door sill trim (three clips).  
15. Pull out the door seal at the left kick panel. Remove the left kick panel (three clips).

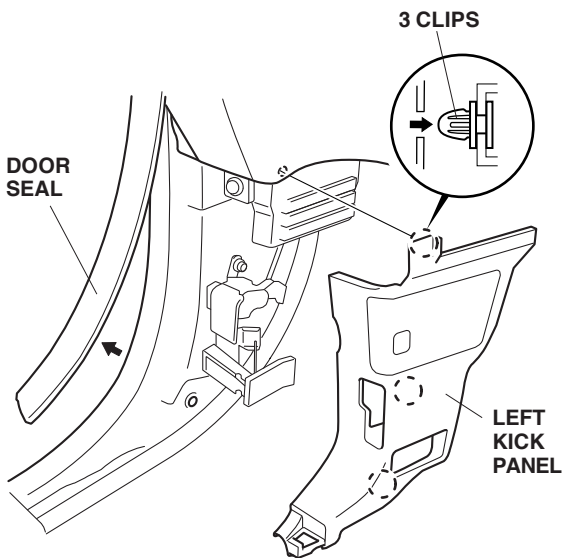

16. Remove the right kick panel the same way (two clips).

17. Open the glove box. Remove the two stoppers by releasing the two retaining tabs for each stopper. Remove the glove box damper cover, and remove the damper rod. Remove the glove box (two screws).

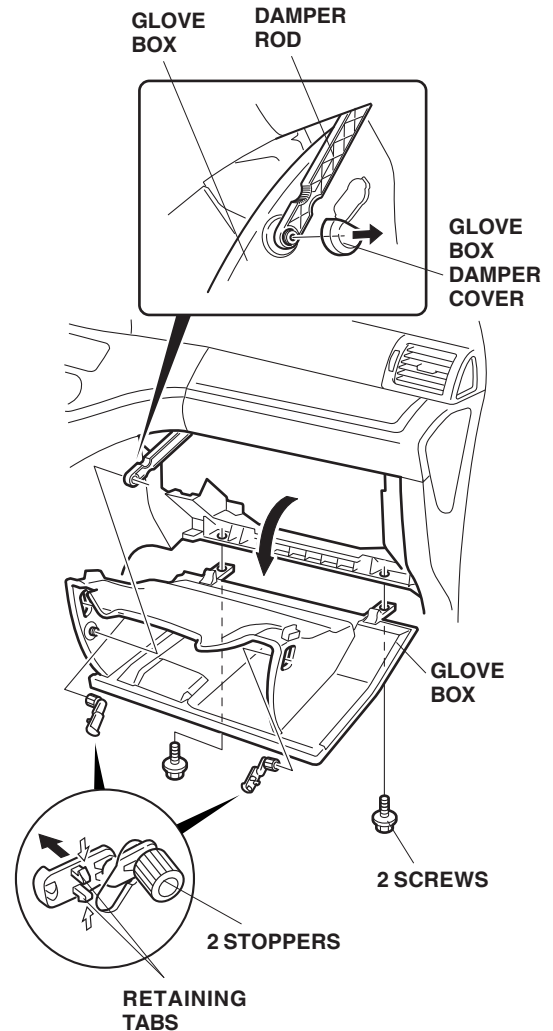

18. Plug the subharness 7-pin connector into the day/night mirror.

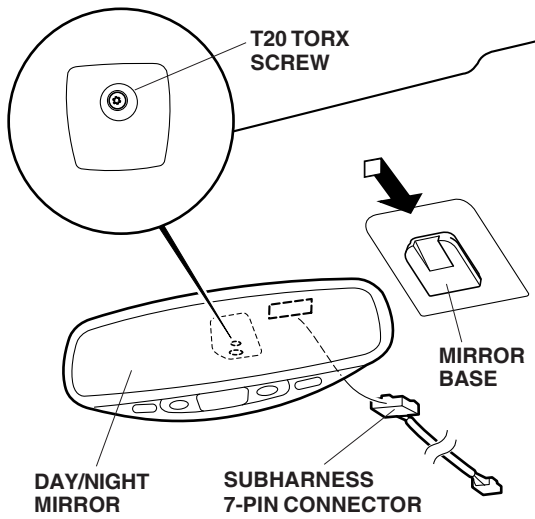

19. Install the day/night mirror to the mirror base.
20. Secure the day/night mirror to the mirror base by tightening the T20 Torx screw.
21. Route the subharness under the headliner, and pull it out through the roof console opening.

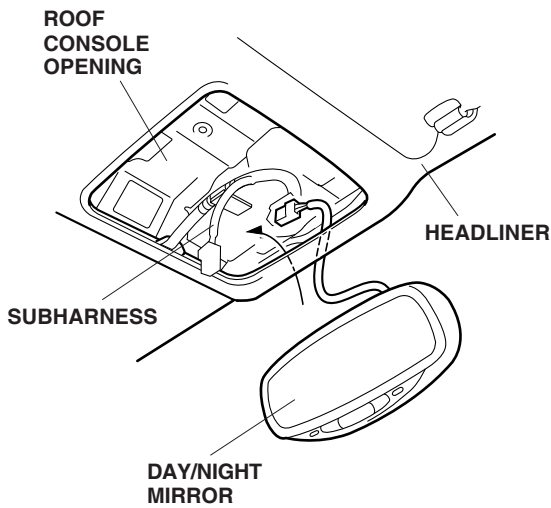

## Routing the Mirror Harness

22. Plug the subharness connector into the mirror harness connector.

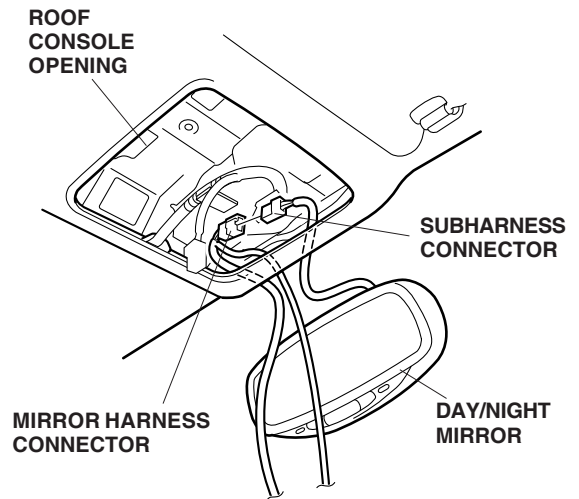

23. Attach the mirror harness connector to the vehicle panel with one EPT sealer as far forward as possible.

NOTE: Do not cover the console bolt hole.

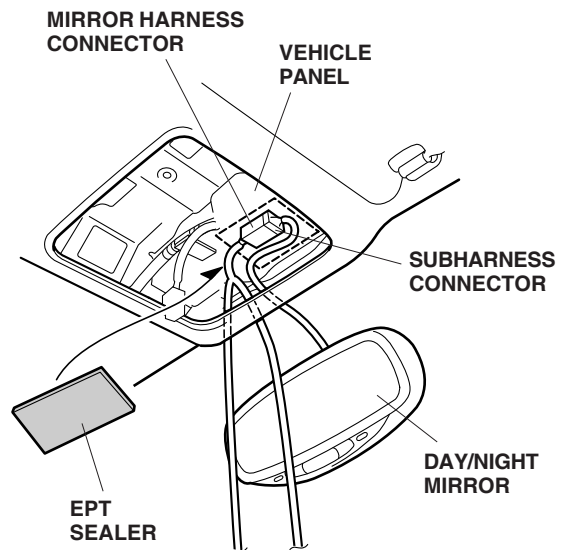

24. Route the terminal from the mirror harness under the headliner toward the right side of the vehicle.

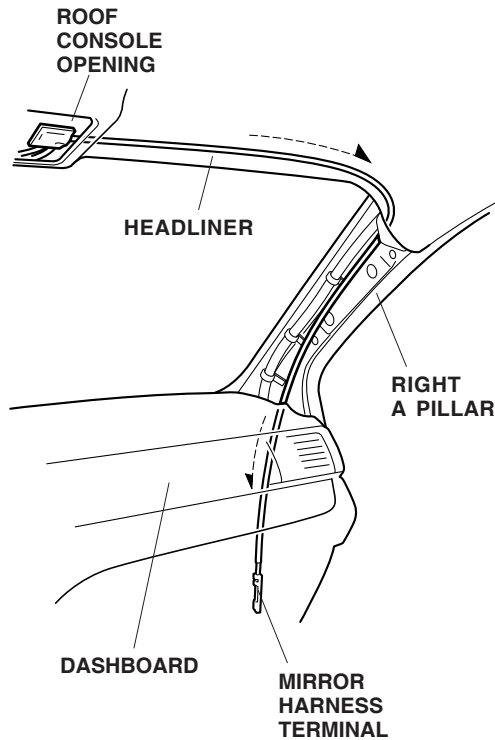

25. Continue routing the mirror harness down the right A pillar and behind the dashboard.
26. Locate the 22-pin connector below the dashboard at the kick panel area. Disconnect the vehicle 22-pin connector, and insert the mirror harness terminal into the vehicle 22-pin connector at the location shown.

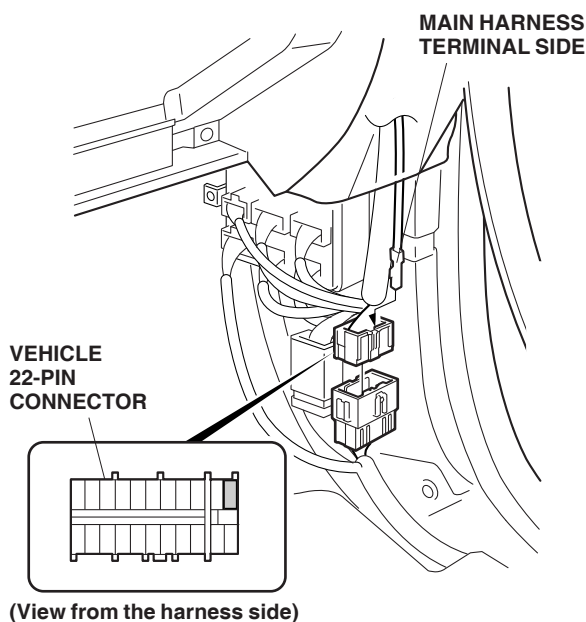

27. Secure the mirror harness to the vehicle harness using two wire ties.

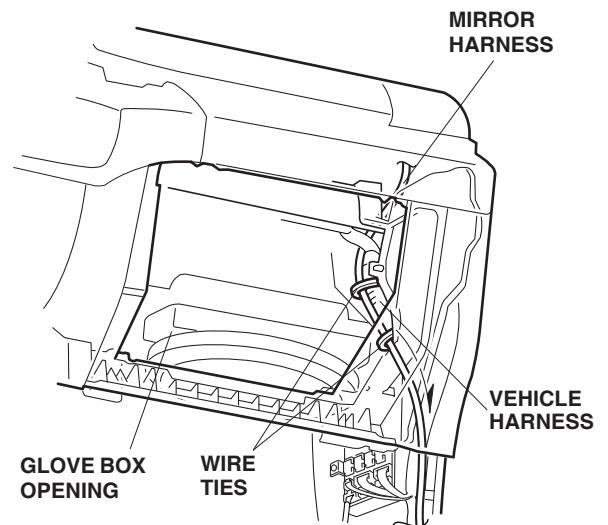

28. Using isopropyl alcohol on a shop towel, clean the right A pillar area where the mirror harness will attach. Attach the mirror harness to the right A pillar using four cushion tapes.

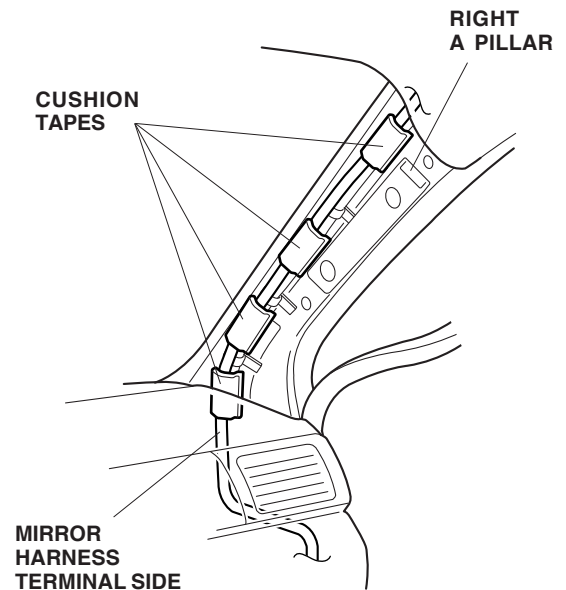

29. Using isopropyl alcohol on a shop towel, clean the headliner area where the mirror harness will attach. Using scissors, cut two EPT sealers in half. Using three halves of EPT sealers, attach the mirror harness to the vehicle panel.

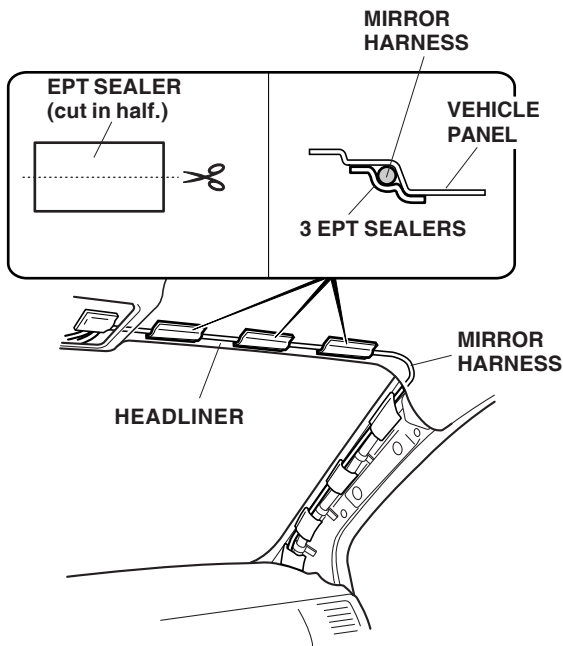

30. Route the ground terminal end from the mirror harness along the headliner and down the left A pillar towards the left fuse box.

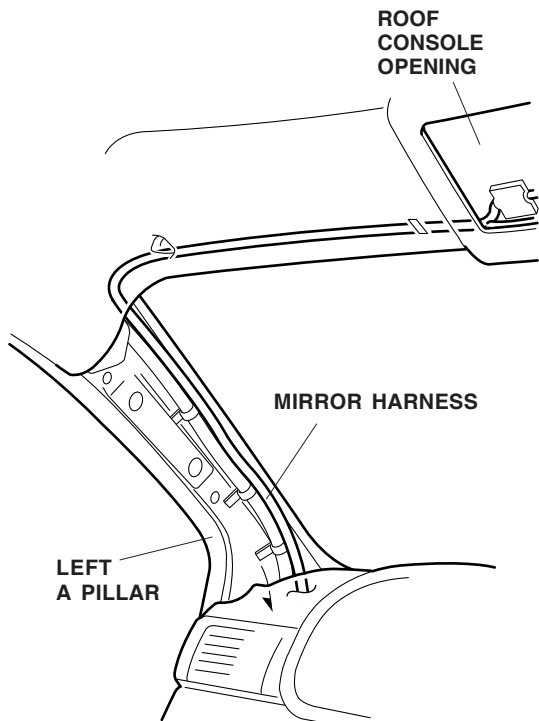

31. Plug the mirror harness 6-pin connector into the 6-pin opening in the fuse box.

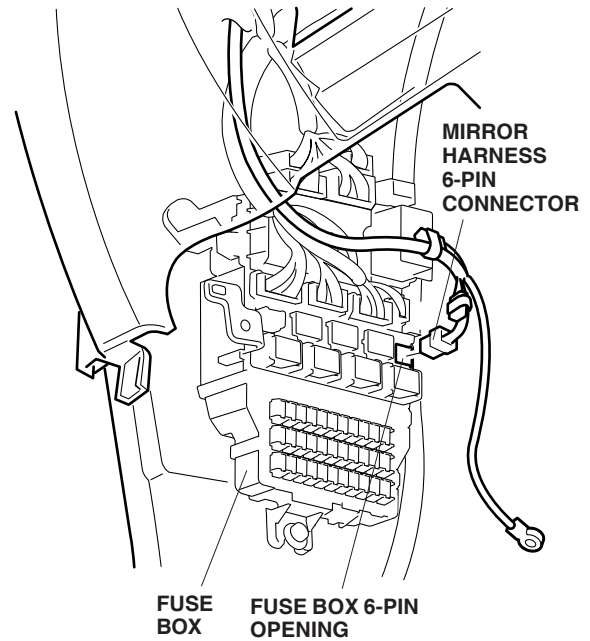

NOTE: If another accessory is already plugged into the 6-pin connector, remove the dummy connector from the 6-pin connector taped to the day/night harness. Plug the 6-pin connector from the other accessory harness into the 6-pin connector from the day/night harness you just unplugged, and plug the day/night harness into the fuse box.

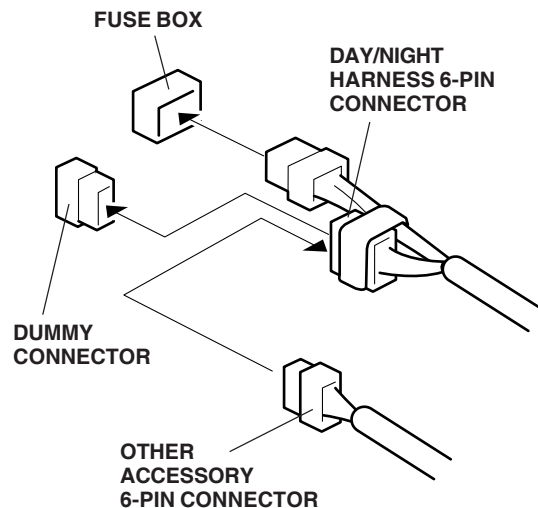

32. Remove the top bolt from the fuel door release. Attach the ground terminal from the mirror harness, and reinstall the fuel door release top bolt using the ground bolt supplied.

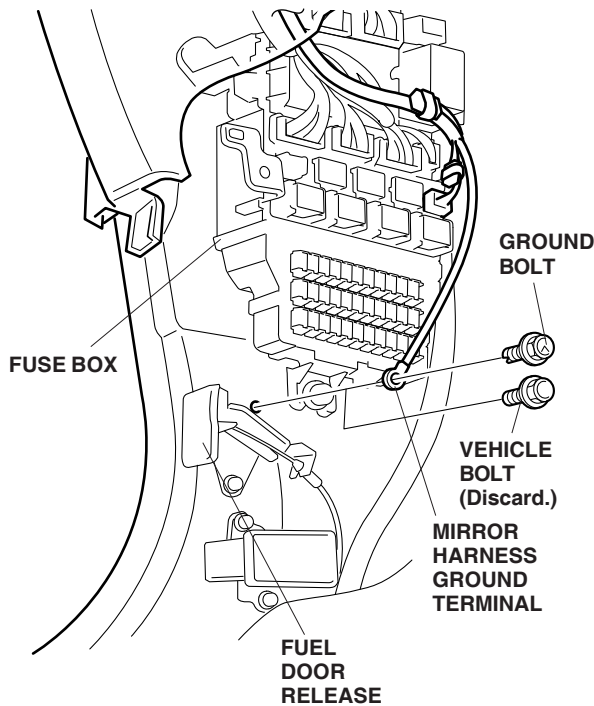

33. Secure the mirror harness to the vehicle harness using two wire ties.

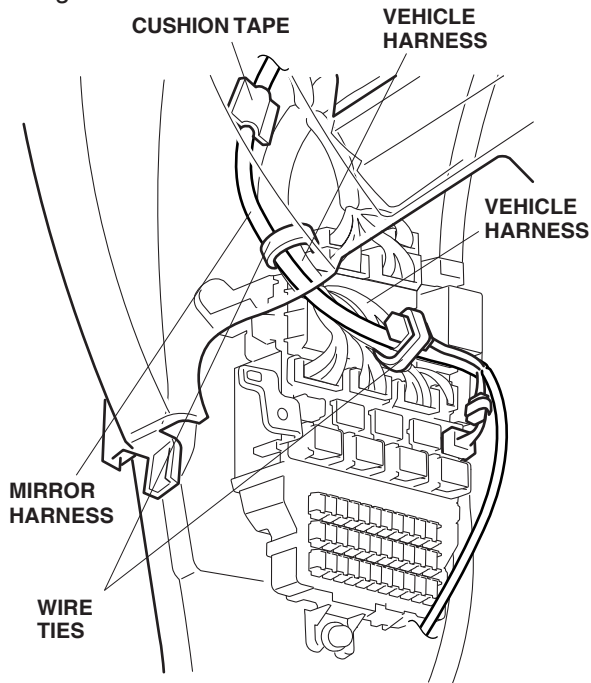

34. Using isopropyl alcohol on a shop towel, clean the vehicle panel. Attach the mirror harness to the vehicle panel using one cushion tape.

35. Along the left A pillar area, secure the mirror harness to the vehicle harness using four wire ties.

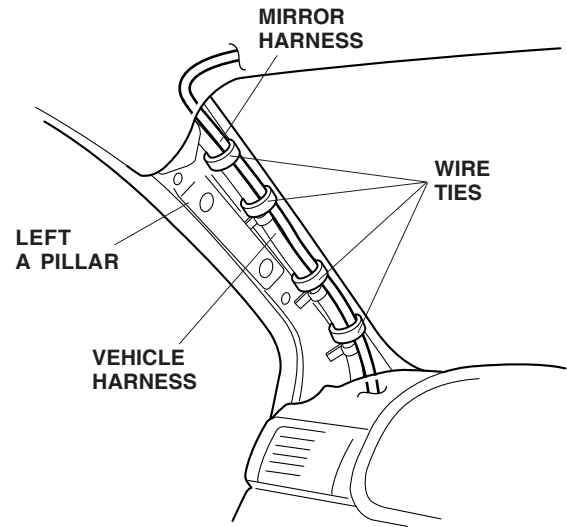

36. Using scissors, cut one EPT sealer in half. Using isopropyl alcohol on a shop towel, clean the headliner area. Secure the mirror harness to the headliner using three pieces of EPT sealer (one piece was cut in step 29).

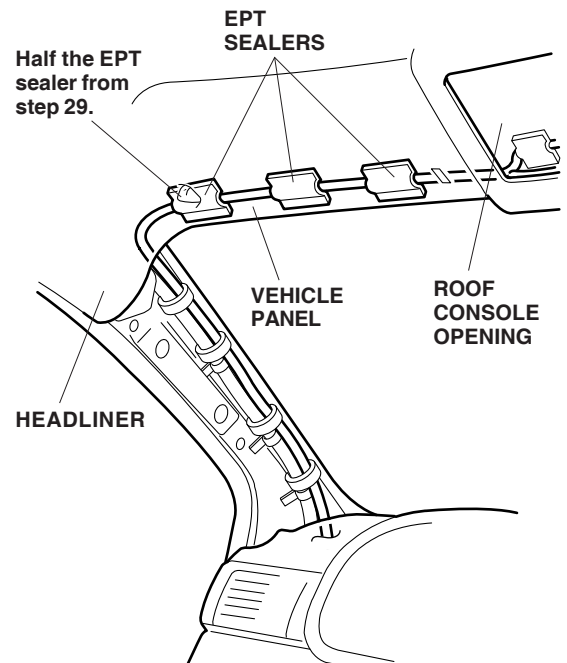



37. Install the wire cover from the day/night mirror to the headliner.

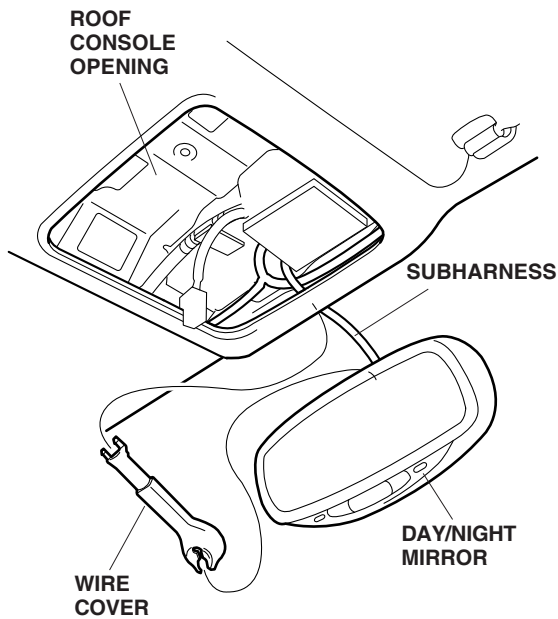

38. Reinstall all removed parts.
39. Reconnect the negative cable to the battery.
40. Enter the customer's radio anti-theft code, and reset the radio station presets.
41. Reset the clock.
42. If equipped, check the operation of the XM radio according to the vehicle owner's manual.

**NOTE:** Whenever the battery is disconnected, the driver's AUTO function is disabled.

- Start the engine. Push down on the driver's window switch until the window is fully open.
- Pull up on the driver's window switch to close the window completely, then hold the switch for 2 seconds or more.
- Test the AUTO window function.